

Kit AiM Solo/SoloDL per Suzuki GSX-R

Guida all'installazione

Fig. 1 sinistra

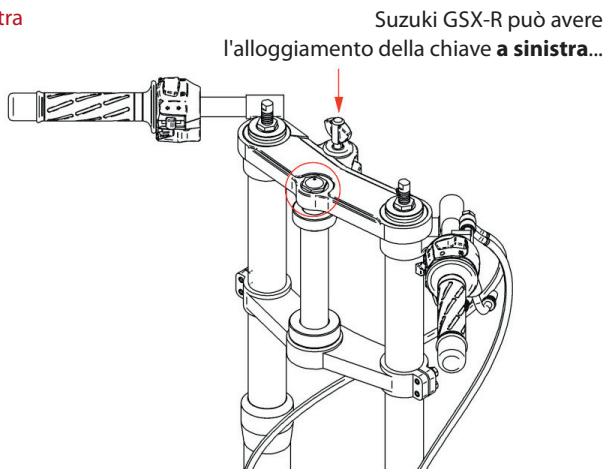

Fig. 1 destra

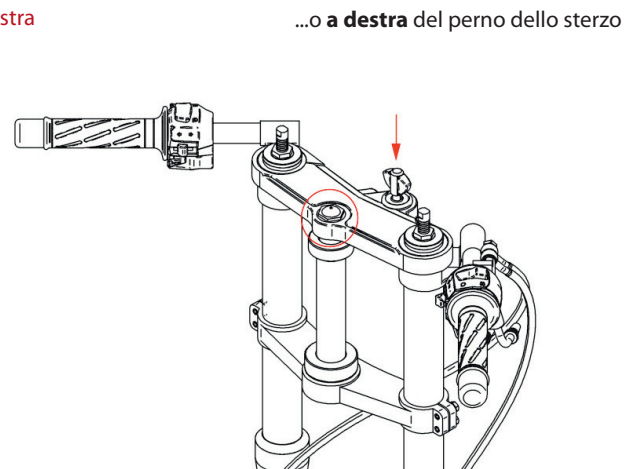

Fig. 2 sinistra

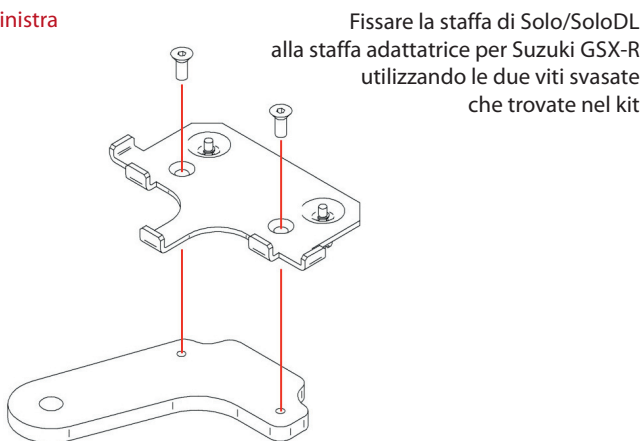

Fig. 2 destra

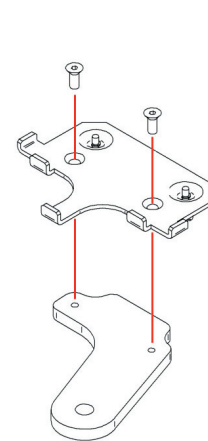

Fig. 3 sinistra

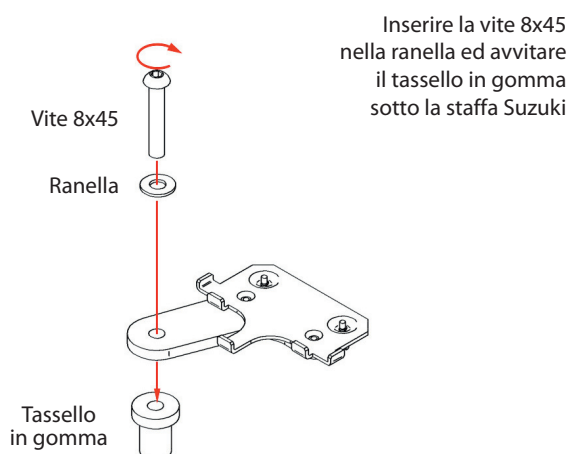
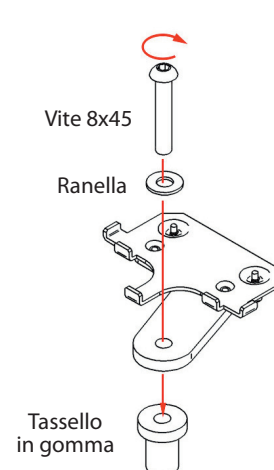

Fig. 3 destra



Kit AiM Solo/SoloDL per Suzuki GSX-R

Guida all'installazione

Fig. 4 sinistra

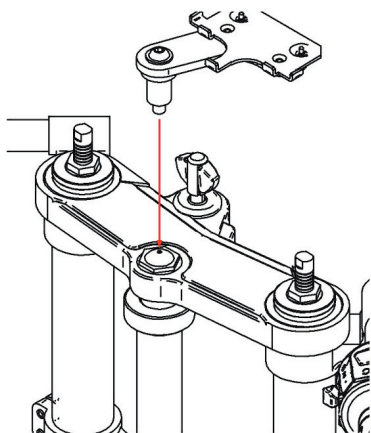

Inserire il kit assemblato nel perno dello sterzo sino a che il distanziale va in battuta sul perno

Fig. 4 destra

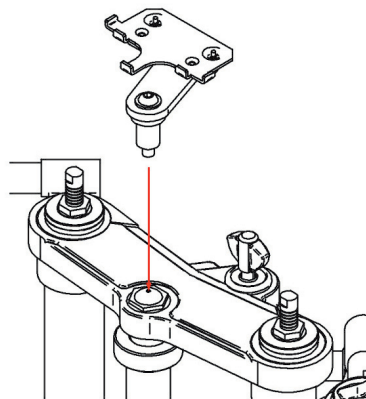
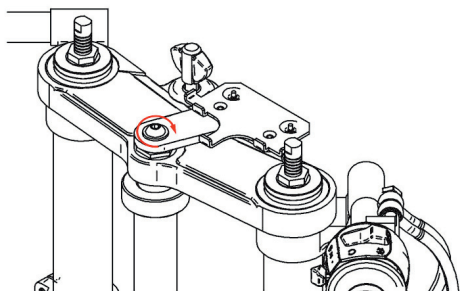

Fig. 5 sinistra



Avvitare la vite centrale sul perno in modo che questo faccia presa e sia ben saldo

Fig. 5 destra

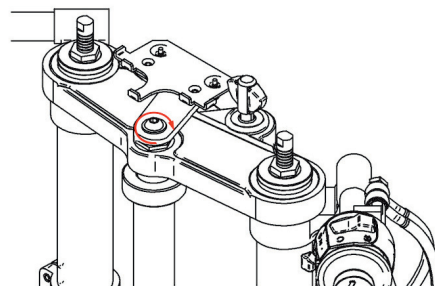
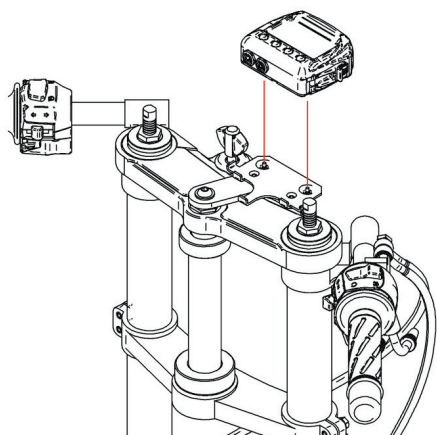
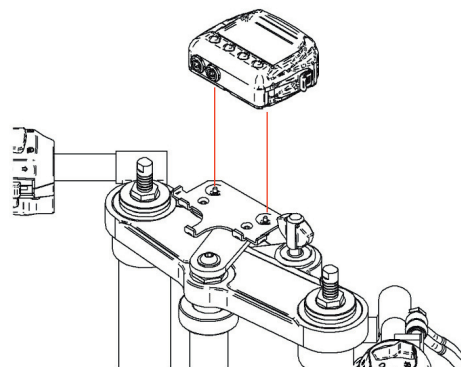

Fig. 6 sinistra



Alloggiare Solo/SoloDL sulla sua staffa

Fig. 6 destra



Kit AiM Solo/SoloDL per Suzuki GSX-R

Guida all'installazione

Fig. 7 sinistra

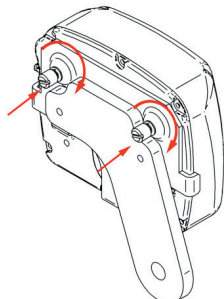

Fissarlo utilizzando viti già inserite sul retro della staffa di Solo/SoloDL

Fig. 7 destra

