

AiM User Guide

SoloDL installation kit for Microtec M222 ECU

Release 1.01



KIT



This user guide explains how to connect Microtec M222 ECU to AiM SoloDL. It is an aftermarket product installed on Honda bikes only. Please refer to Microtec website “www.microtec.cc” to know supported bike models.

1

Installation notes

To install SoloDL on your bike you can use a bar pad. AiM provides the two optional bar pads shown below:

- bar pad for handle bar with cross brace – part number: **DNKTKPMSOL1** image on the left;
- bar pad for handle bar without cross brace – part number: **DNKTKPMSOLO** image on the right.



Microtec M222 ECU can be connected to SoloDL using the connection kit shown here below, part number is: **V02569260**. Bottom of it is the connection scheme.

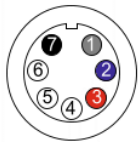

7 pins Binder 712 male connector pinout solder termination view

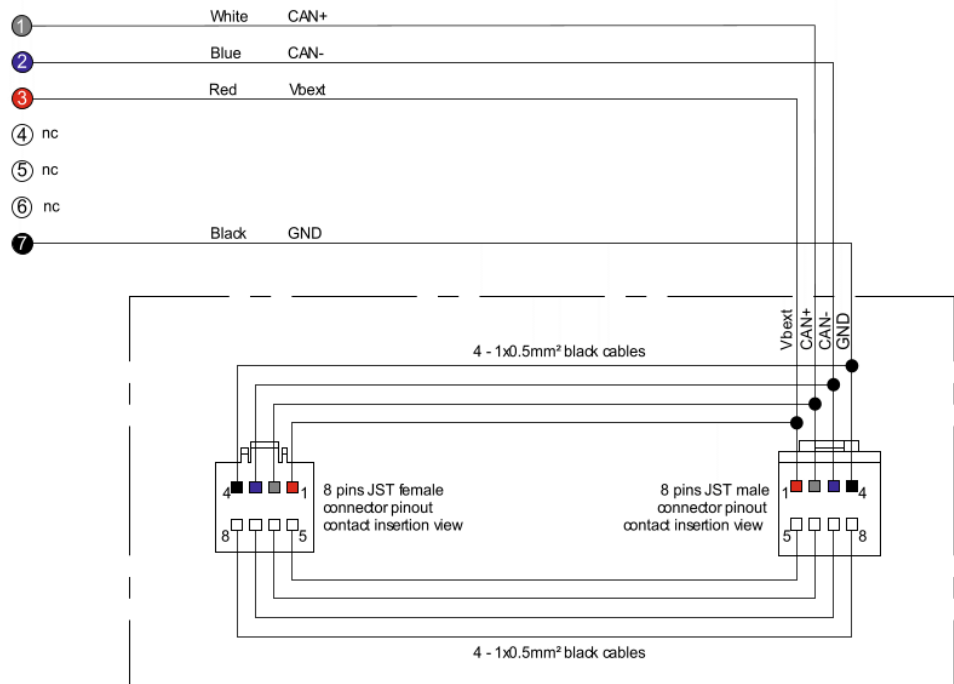

M222 ECU is placed under the bike seat and has a connector used to communicate data to an external device. Make it pass along the side of the bike and plug it to AiM cable.



Please note: Microtec ECU powers SoloDL. It is thereby unnecessary to check SoloDL battery status.

In case Microtec ECU is already connected to an external device it is possible to maintain this connection using the connection kit. As explained in the drawing below, M222 ECU can be connected to AiM male connector labelled "To the ECU" and the third device can be connected to the ECU through AiM cable female connector labelled "To other devices".

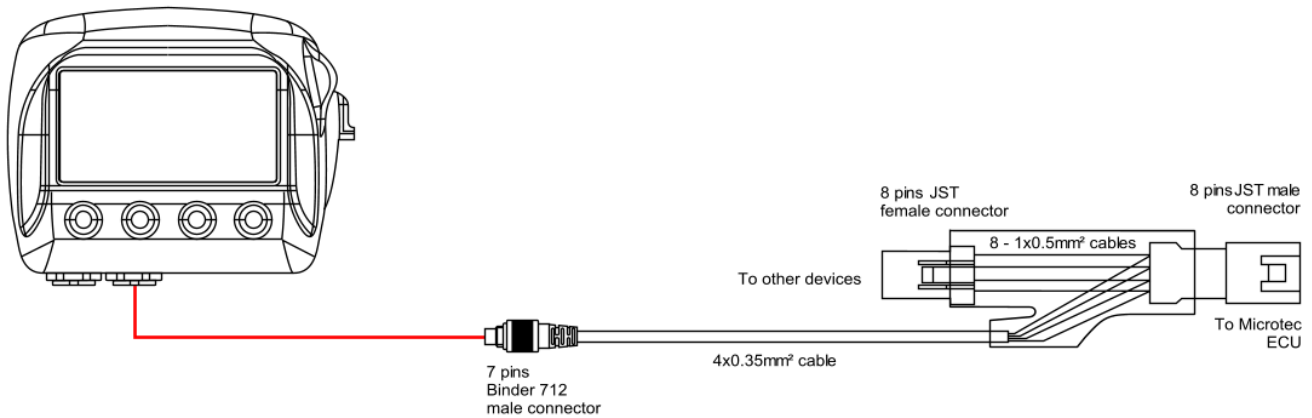

ECU connector has a cap on it. If the ECU is only connected to SoloDL remove the cap and place it on AiM kit female connector (labelled "to other devices" here above) and connect AiM kit male connector to the ECU female connector.

2 ECU Software setup

Before connection to SoloDL, Microtec ECU needs to be setup via MON software. ECU channel frequency is to be set on 50 or 100Hz value. Please refer to MON software user guide to know how to perform this operation. As an example we are showing here below channel frequency setting page of MON172 software.

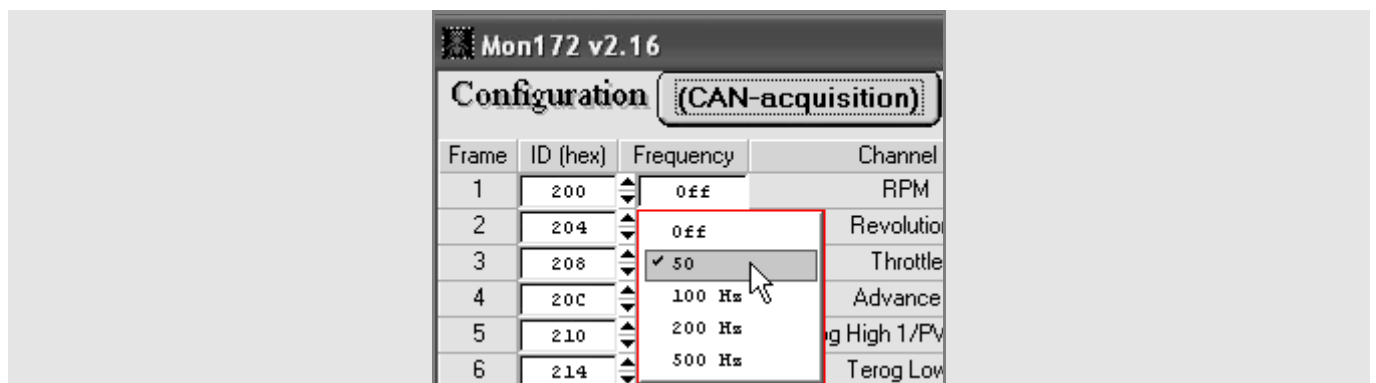

3

Configuration with Race Studio 2

Before connecting SoloDL to the ECU, set it up using Race Studio 2 software. The parameters to select in the device configuration are:

- ECU Manufacturer "Microtec"
- ECU Model "M222".

4

Available channels

Channels received by SoloDL connected to "Microtec" "M222" protocol are:

ID	CHANNEL NAME	FUNCTION
ECU_1	MT_RPM	RPM
ECU_2	MT_ENG_ACC	Engine acceleration
ECU_3	MT_TPS	Throttle position
ECU_4	MT_DEV_TPS	Throttle position derivative
ECU_5	MT_ECT	Engine coolant temperature
ECU_6	MT_TAIR	Intake air temperature
ECU_7	MT_BARO	Barometric pressure
ECU_8	MT_MAP	Manifold air pressure
ECU_9	MT_BATT	Battery supply
ECU_10	MT_GEAR	Engaged gear
ECU_11	MT_LAMBDA	Lambda value
ECU_12	MT_MAP_INDEX	Manifold air pressure index
ECU_13	MT_INJ_PHASE	Injection phase
ECU_14	MT_INJ_TIME	Injection time
ECU_15	MT_INJ_BASE	injection base time
ECU_16	MT_ING_ADV	Ignition advance



ECU_17	MT_ING_BASE	ignition base angle
ECU_18	MT_COR_INJ_H2O	Injection correction from water temperature
ECU_19	MT_COR_INJ_AIR	Injection correction from air temperature
ECU_20	MT_COR_INJ_MAP	Injection correction from manifold air pressure
ECU_21	MT_COR_INJ_AUX	Injection auxiliary correction
ECU_22	MT_COR_INJ_ENG	Injection correction from engine temperature
ECU_23	MT_OFF_IGN_H2O	Offset ignition from water temperature
ECU_24	MT_OFF_IGN_AIR	Offset ignition from air temperature
ECU_25	MT_OFF_ING_MAP	Offset ignition from manifold air pressure
ECU_26	MT_OFF_ING_AUX	Auxiliary ignition offset
ECU_27	MT_OFF_IGN_ENG	Offset ignition from engine temperature
ECU_28	MT_DWELL	Dwell time

Technical note: not all data channels outlined in the ECU template are validated for each manufacturer model or variant; some of the outlined channels are model and year specific, and therefore may not be applicable.