

AiM Infotech

Ferrari  
F430 Challenge,  
F430 GT3,  
F430 GT3 Scuderia

Release 1.04

---



ECU



This tutorial explains how to connect Ferrari racing cars to AiM devices. Supported years are:

- Ferrari F430 Challenge from 2007 onwards
- Ferrari F430 GT3 from 2006 onwards
- Ferrari F430 GT3 Scuderia from 2009 onwards

**Please note:** a dedicated AiM ECU Bridge kit for these cars is available: part number **X90BGFF43MA**

# 1

## CAN lines

---

Ferrari F430 Challenge, F430 GT3 and F430GT3 Scuderia feature 2 Bosch ECUs and communicate using the CAN Bus. The vehicle has two CAN lines both AiM compatible. They are:

- “F430 (ECU Bosch)” **recommended**: connects the vehicle control units – among which are two Marelli ECUs – using two 4 pins Superseal connectors;
- “F430C (Marelli DDU)”’: connects Marelli Dash to Marelli logger using two 6 pins Superseal connectors.

Here below is a scheme of both connections.

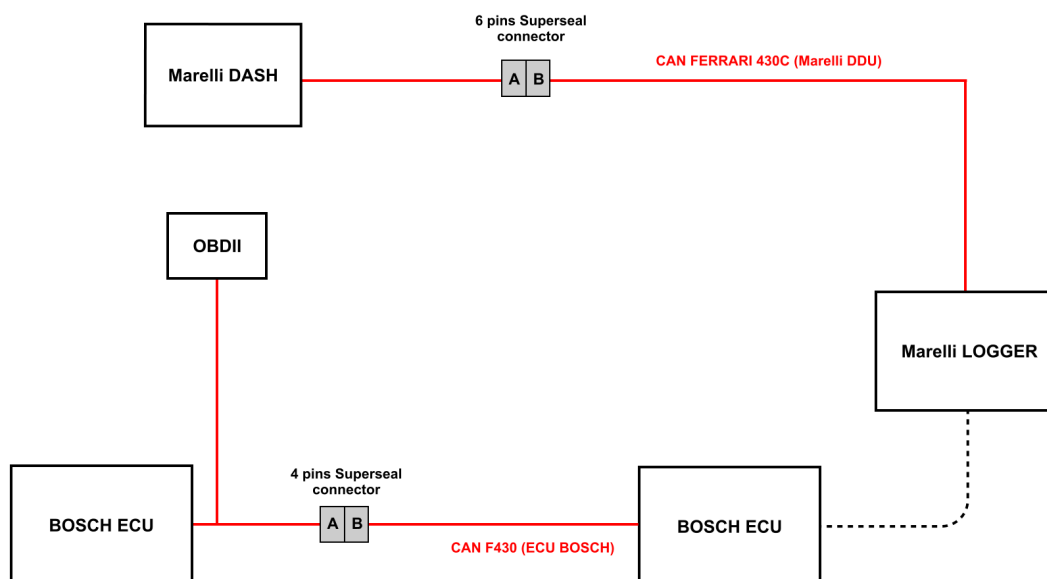

# 1.1

## CAN F430 (ECU Bosch) connection – recommended

This connection is made using the 4 pins Superseal connectors. Split apart the two connectors and connect AiM device following this scheme. **Please note:** pins numbers are printed on the connector.

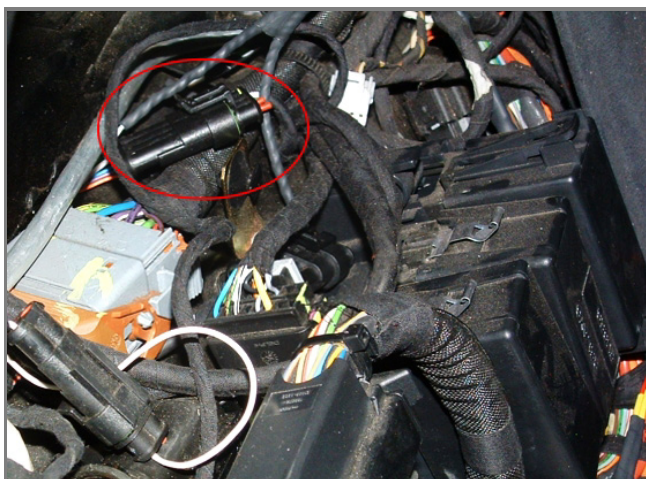
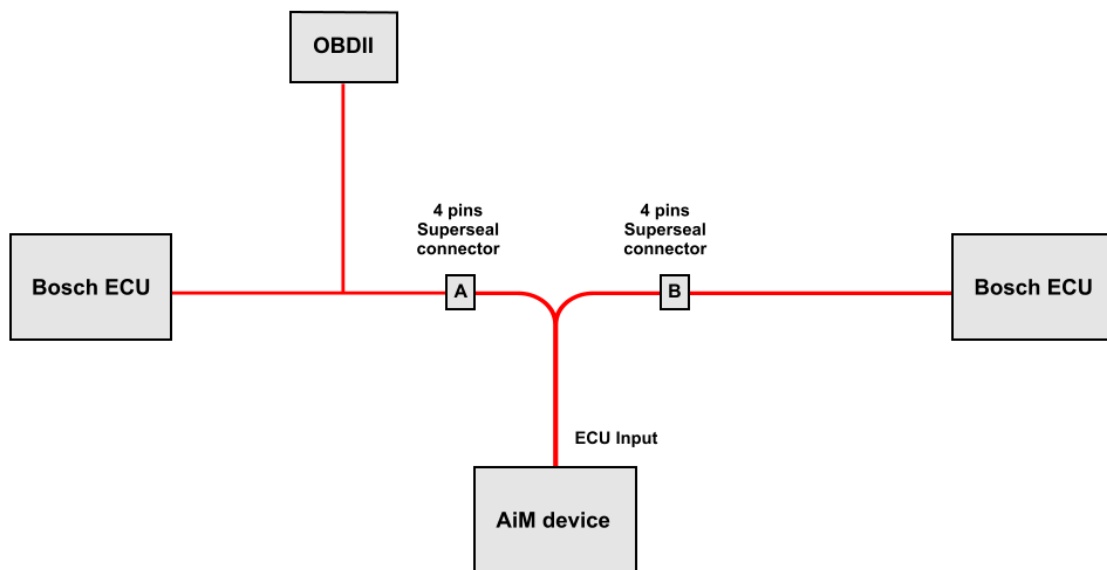

4 pins Superseal connector pin	Pin function	AiM cable label
1	CAN High	CAN+
2	CAN Low	CAN-

## 1.2 CAN F430C (Marelli DDU) connection

This connection is made using the 6 pins Superseal connectors. Here below is the connection scheme.

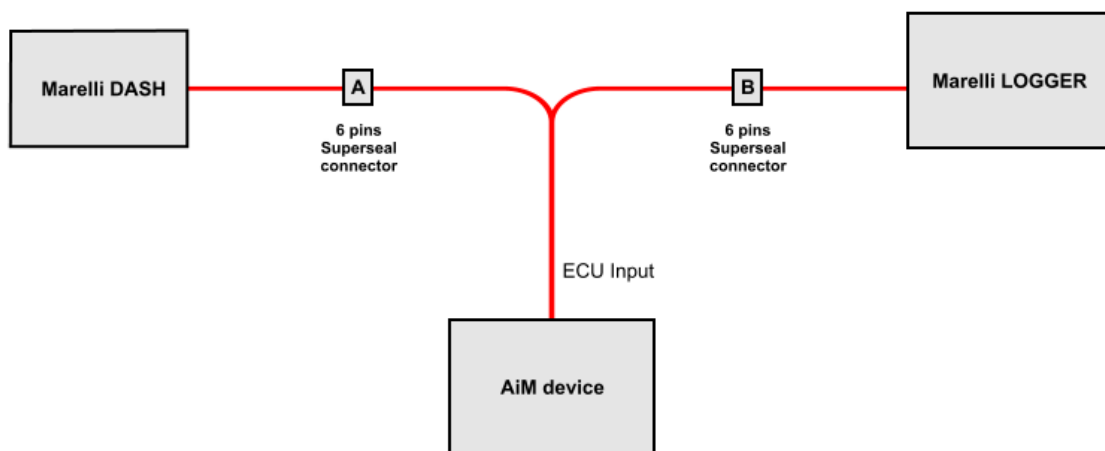

Split apart the two 6 pins Superseal connectors and place AiM device between the two connectors; then follow the table below. Pins number are printed on the connector.

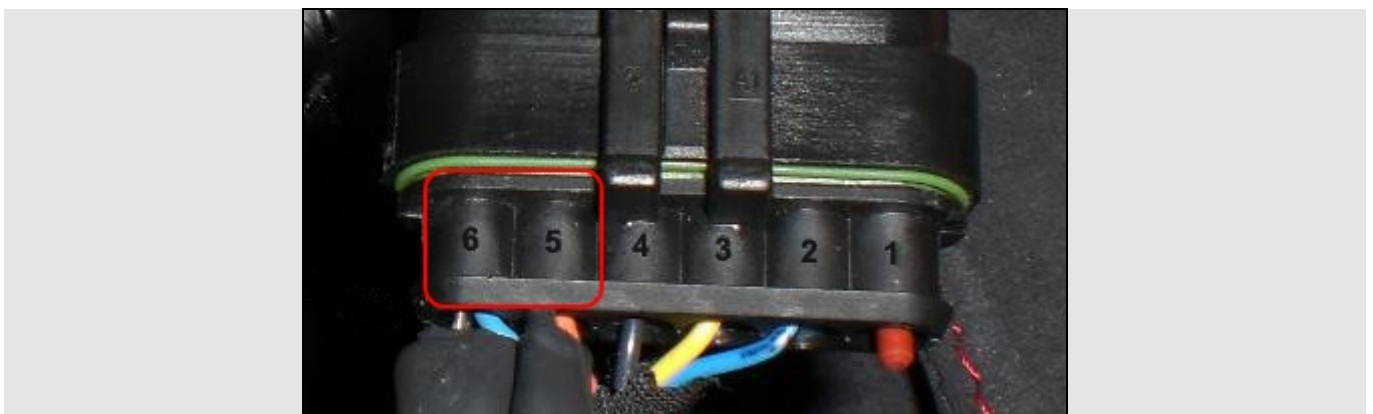

6 pins Superseal connector pin	Pin function	AiM cable label
6	CAN High	CAN+
5	CAN Low	CAN-

## 2

# AIM device configuration

---

Before connecting the ECU to AiM device set this up using AiM Race Studio software. The parameters to select in the device configuration are:

- ECU manufacturer "Ferrari" and, according to the CAN line you are using,
- ECU Model
  - "430 (ECU Bosch)" **or**
  - "430C (Marelli DDU);

## 3

### Available channels

---

Channels received by AiM devices connected to Ferrari F430 Challenge, F430 GT3 and F430 GT3 Scuderia change according to the CAN line you are using.

#### 3.1

### CAN F430 (ECU Bosch) available channels

---

Channels received by AiM devices connected to "Ferrari "430 (ECU Bosch)" protocol are:

ID	CHANNEL NAME	FUNCTION
ECU_1	F430_RPM	RPM
ECU_2	F430_WH_SPD_FL	Front left wheel speed
ECU_3	F430_WH_SPD_FR	Front right wheel speed
ECU_4	F430_WH_SPD_RL	Rear left wheel speed
ECU_5	F430_WH_SPD_RR	Rear right wheel speed
ECU_6	F430_VEH_SPEED	Vehicle speed
ECU_7	F430_PPS	Pedal position
ECU_8	F430_GEAR	Engaged gear
ECU_9	F430_STEER_ANG	Steering angle
ECU_10	F430_BRK_SW	Brake switch
ECU_11	F430_STEER_SPD	Steering wheel speed
ECU_12	F430_ECT	Engine coolant temperature
ECU_13	F430_OILT	Oil temperature
ECU_14	F430_CST	Traction control selection

**Technical note:** not all data channels outlined in the ECU template are validated for each manufacturer model or variant; some of the outlined channels are model and year specific, and therefore may not be applicable.

## 3.2

### CAN F430C (Marelli DDU) available channels

---

Channels received by AIM devices connected to "Ferrari" "430C (Marelli DDU)" are:

ID	CHANNEL NAME	FUNCTION
ECU_1	F430C_RPM	RPM
ECU_2	F430C_SPD_FL	Front left wheel speed
ECU_3	F430C_SPD_FR	Front right wheel speed
ECU_4	F430C_SPD_RL	Rear left wheel speed
ECU_5	F430C_SPD_RR	Rear right wheel speed
ECU_6	F430C_TPS	Throttle position
ECU_7	F430C_ECT	Engine coolant temperature
ECU_8	F430C_OILTEMP	Oil temperature
ECU_9	F430C_FUELLEV	Fuel level
ECU_10	F430C_BRAKE	Brake sensor
ECU_11	F430C_GEAR	Engaged gear
ECU_12	F430C_STR_WHEEL_ANG	Steering wheel angle

**Technical note:** not all data channels outlined in the ECU template are validated for each manufacturer model or variant; some of the outlined channels are model and year specific, and therefore may not be applicable.